

# A.F.H. T-type 1V Die V4 H=60

Allowable Tonnage 750kN/m

88° 86°

FEAT A.F.H. Die Holder

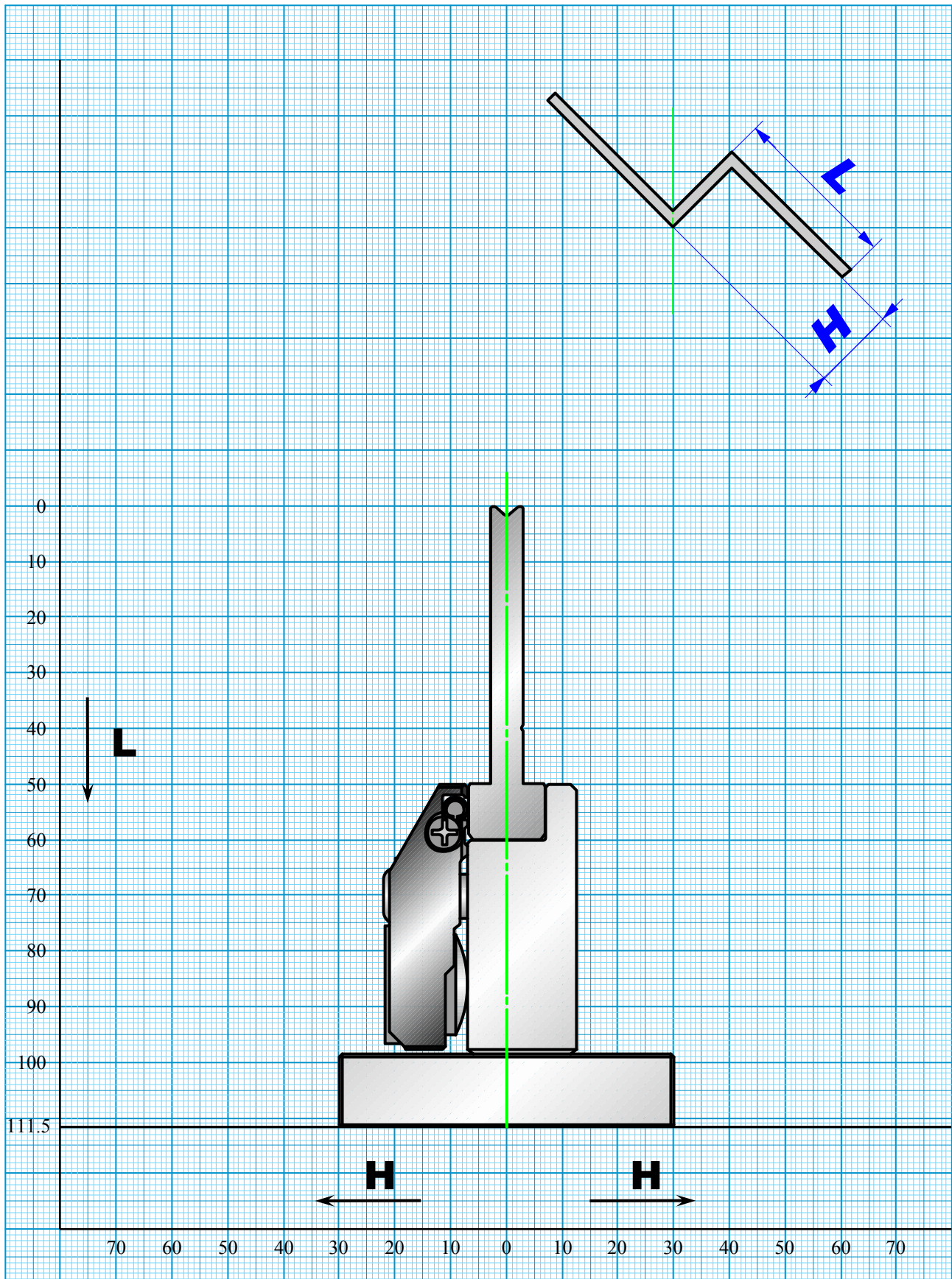

# A.F.H. T-type 1V Die V5 H=60

Allowable Tonnage 750kN/m

88° 86°

FEAT A.F.H. Die Holder

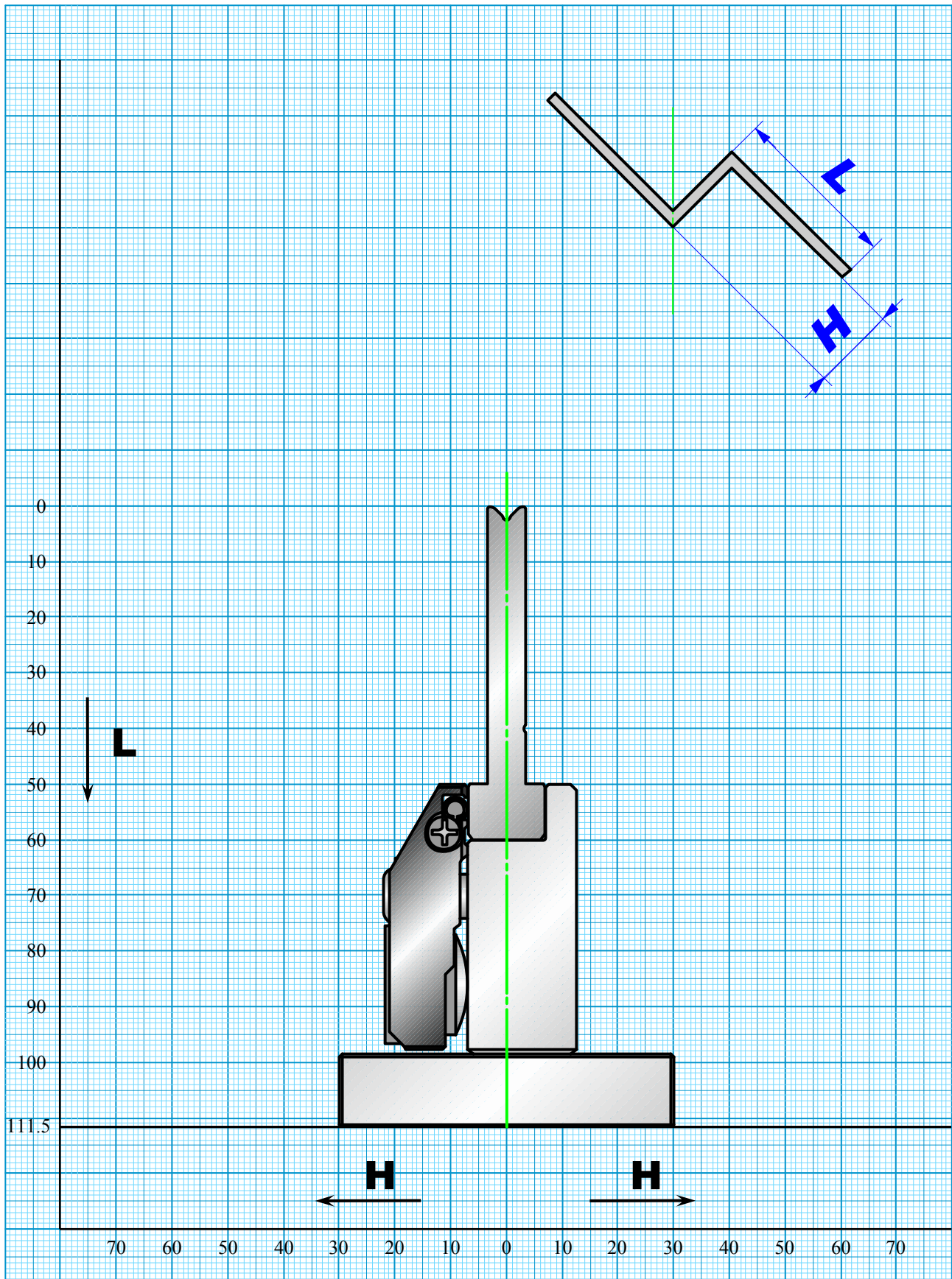

# A.F.H. T-type 1V Die V6 H=60

Allowable Tonnage 800kN/m

88° 86°

FEAT A.F.H. Die Holder

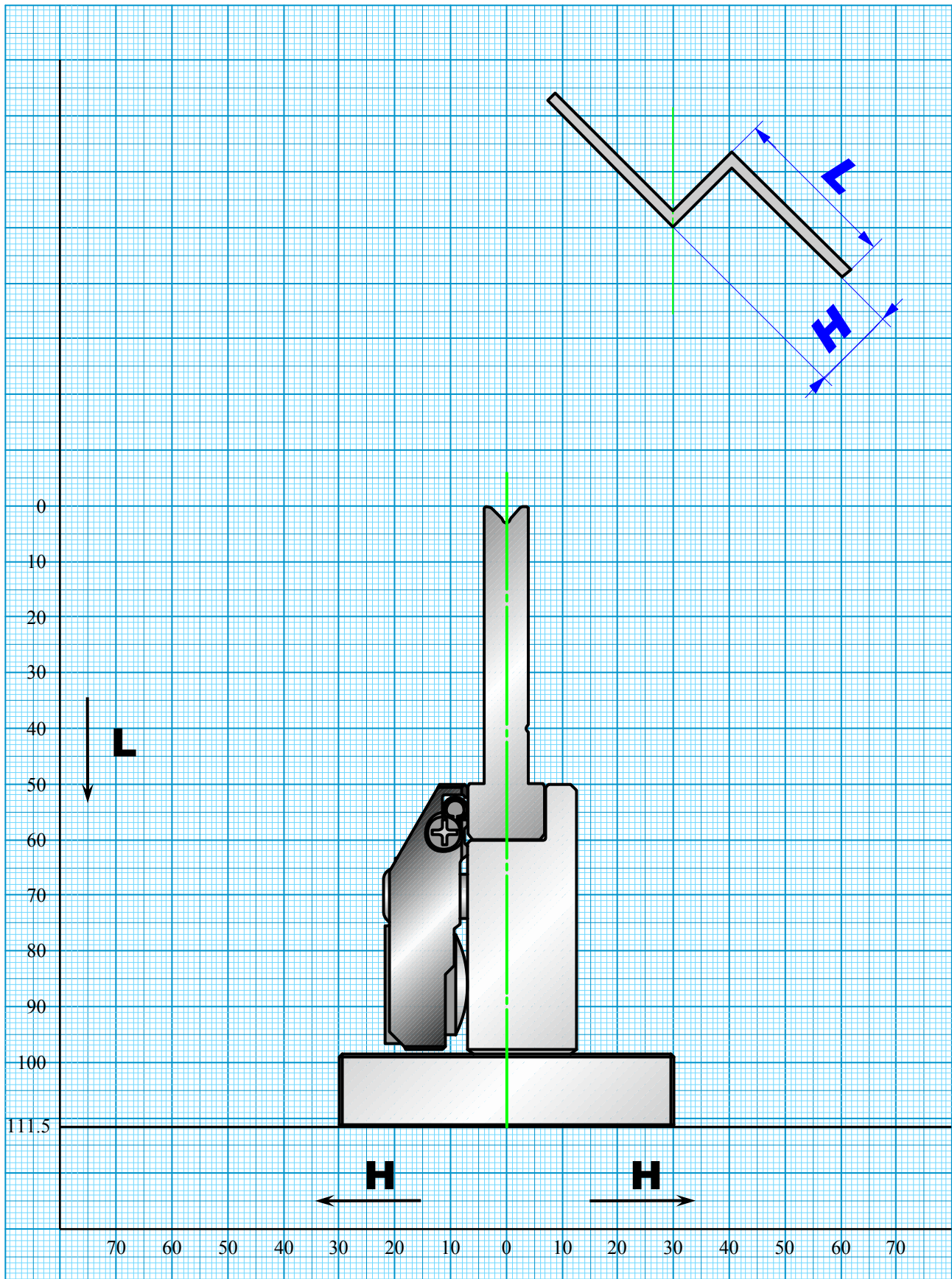

# A.F.H. T-type 1V Die V8 H=60

Allowable Tonnage 900kN/m

88° 86°

FEAT A.F.H. Die Holder

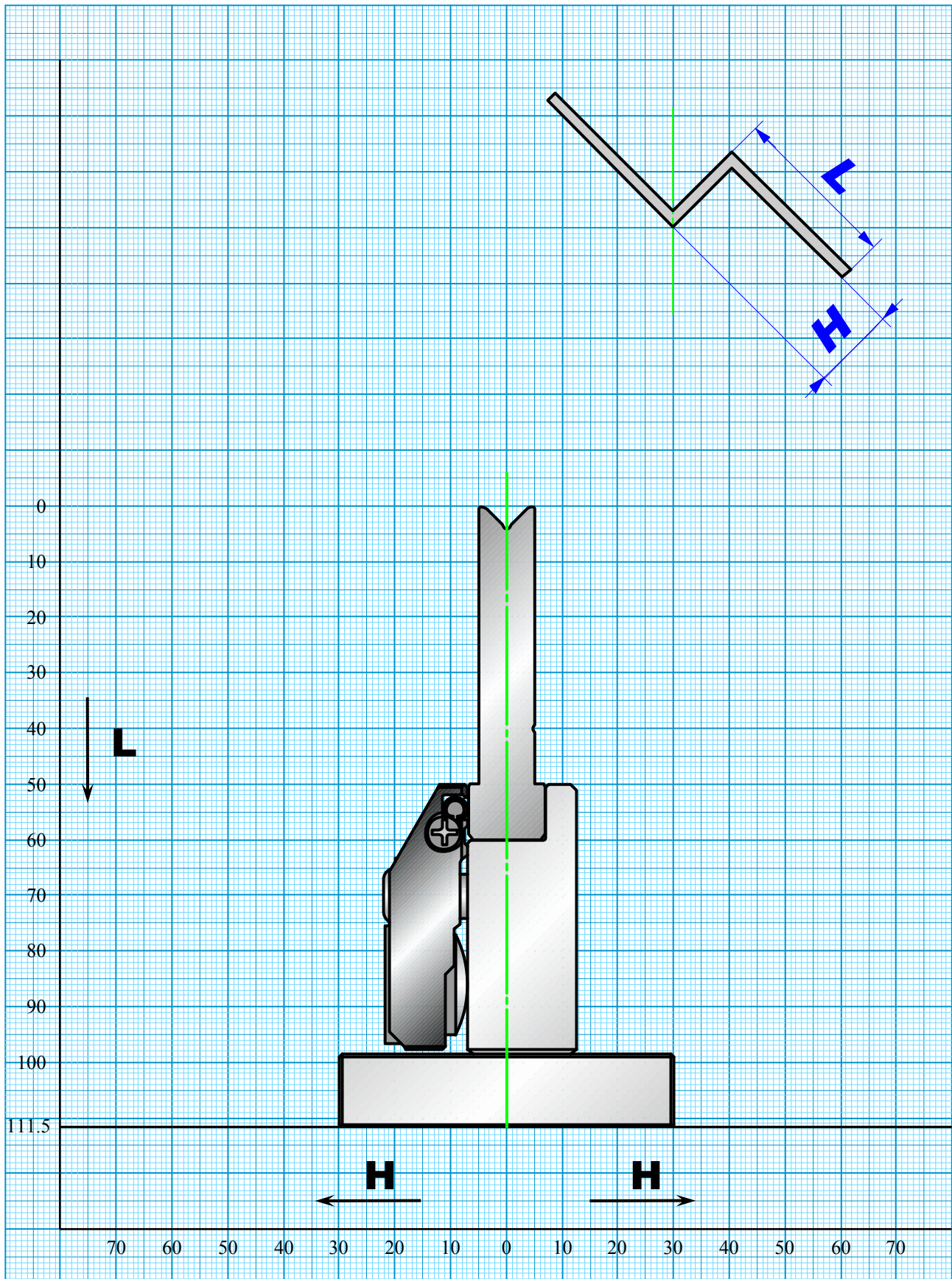

# A.F.H. T-type 1V Die V10 H=60

Allowable Tonnage 1000kN/m

88° 86°

FEAT A.F.H. Die Holder

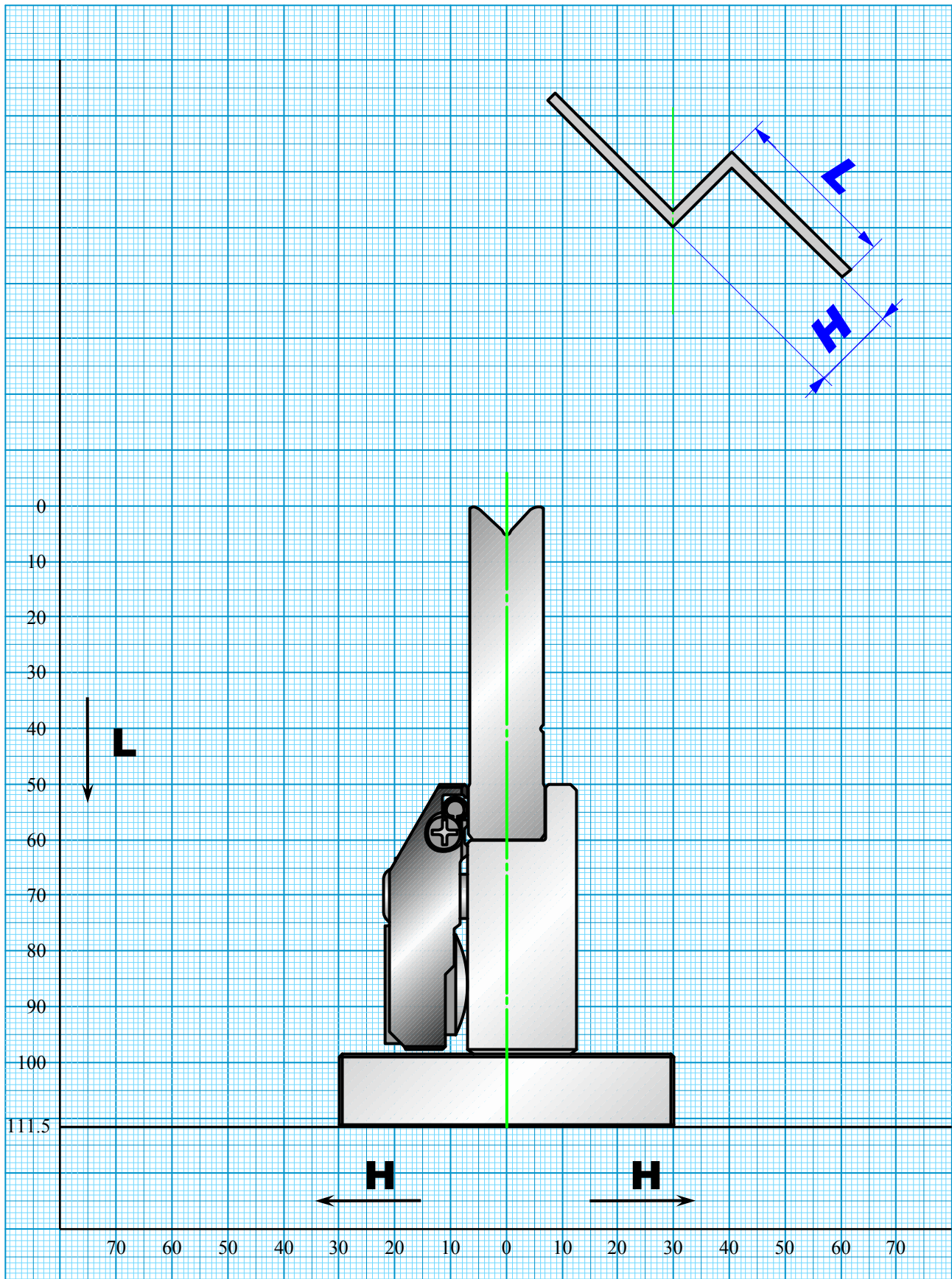



# A.F.H. T-type 1V Die V16 H=60

Allowable Tonnage 1000kN/m

88° 86°

FEAT A.F.H. Die Holder

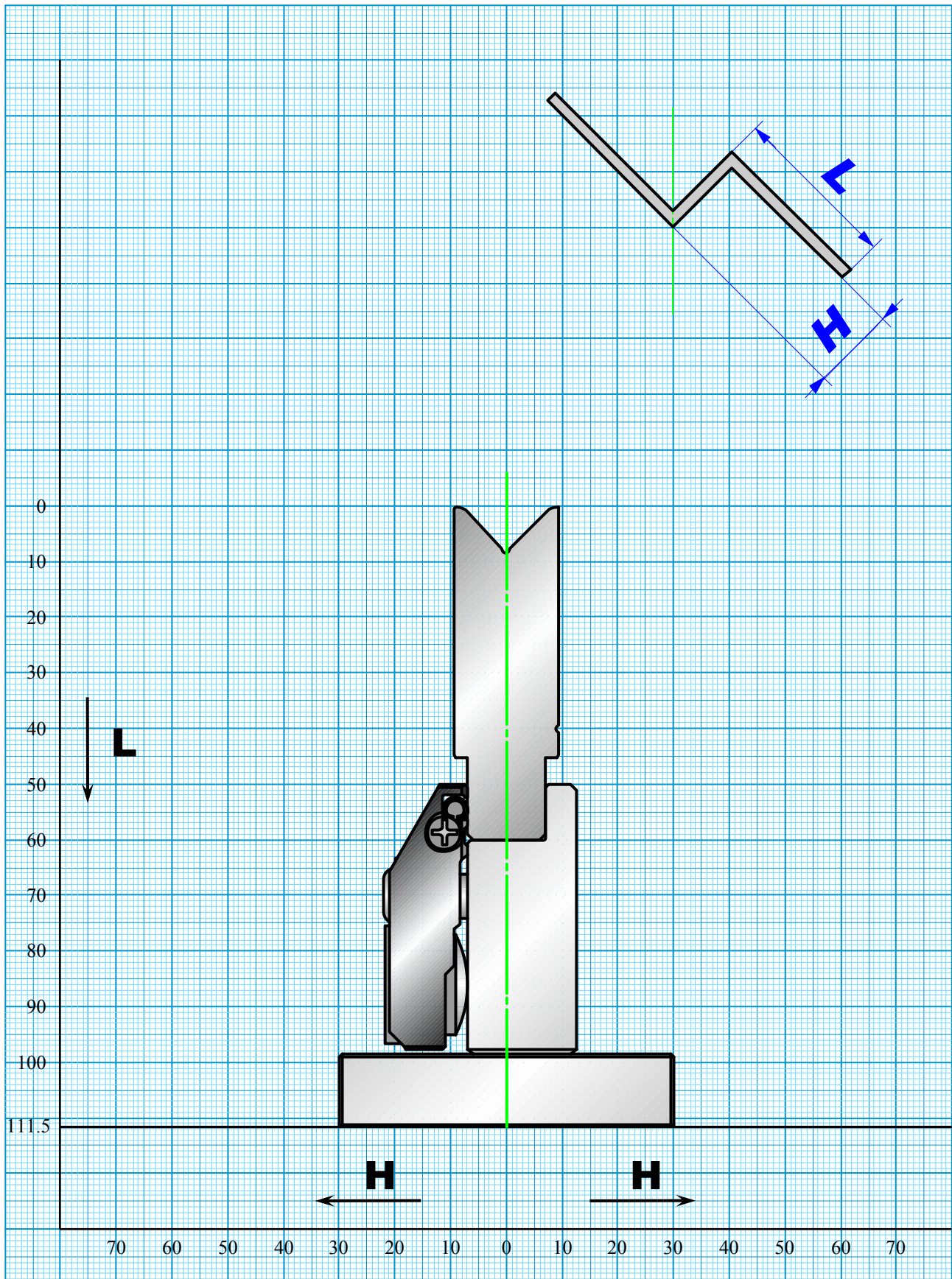

# A.F.H. T-type 1V Die V18 H=60

Allowable Tonnage 1000kN/m

88° 86°

FEAT A.F.H. Die Holder

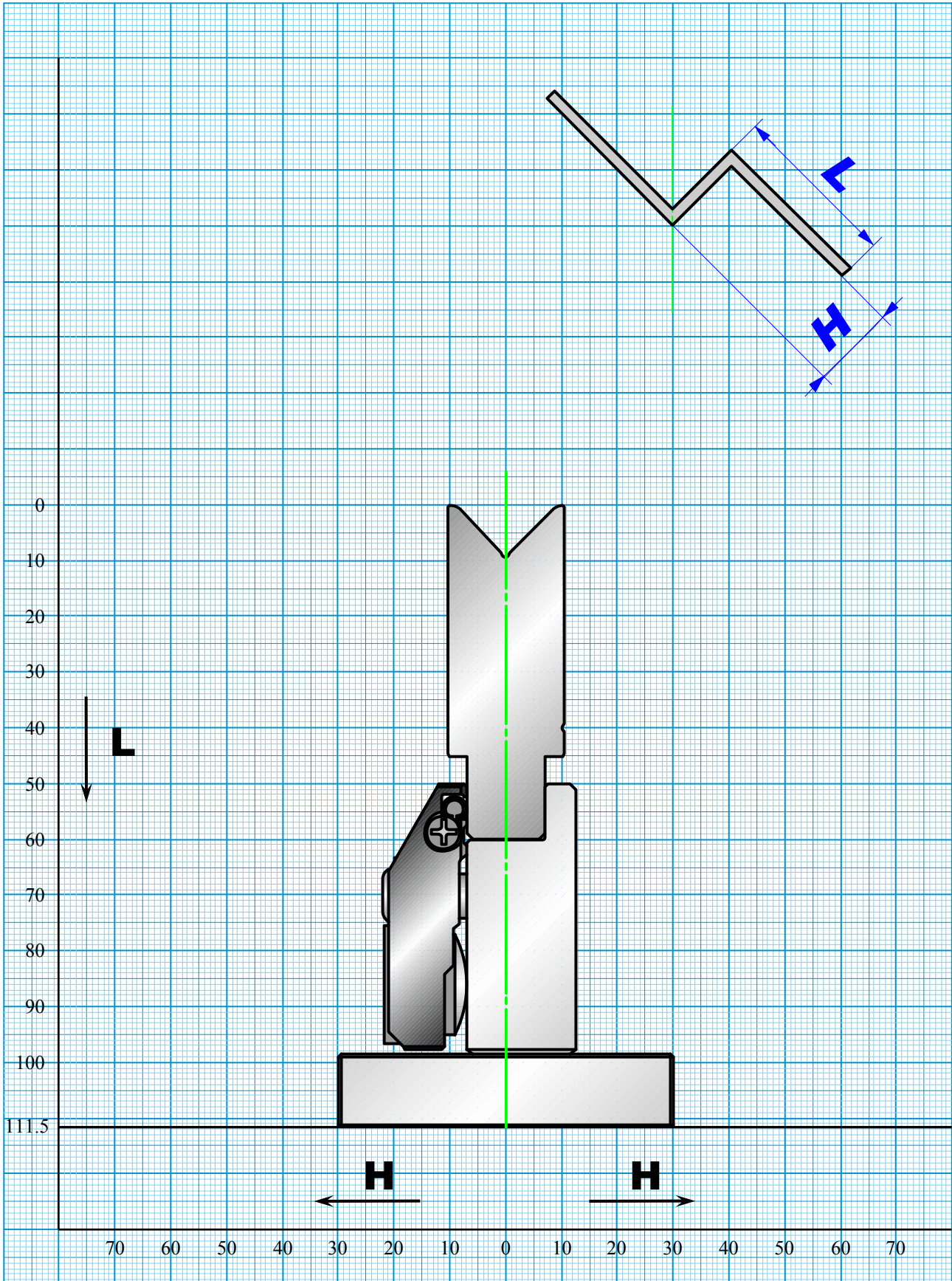

# A.F.H. T-type 1V Die V20 H=60

Allowable Tonnage 1000kN/m

88° 86°

FEAT A.F.H. Die Holder

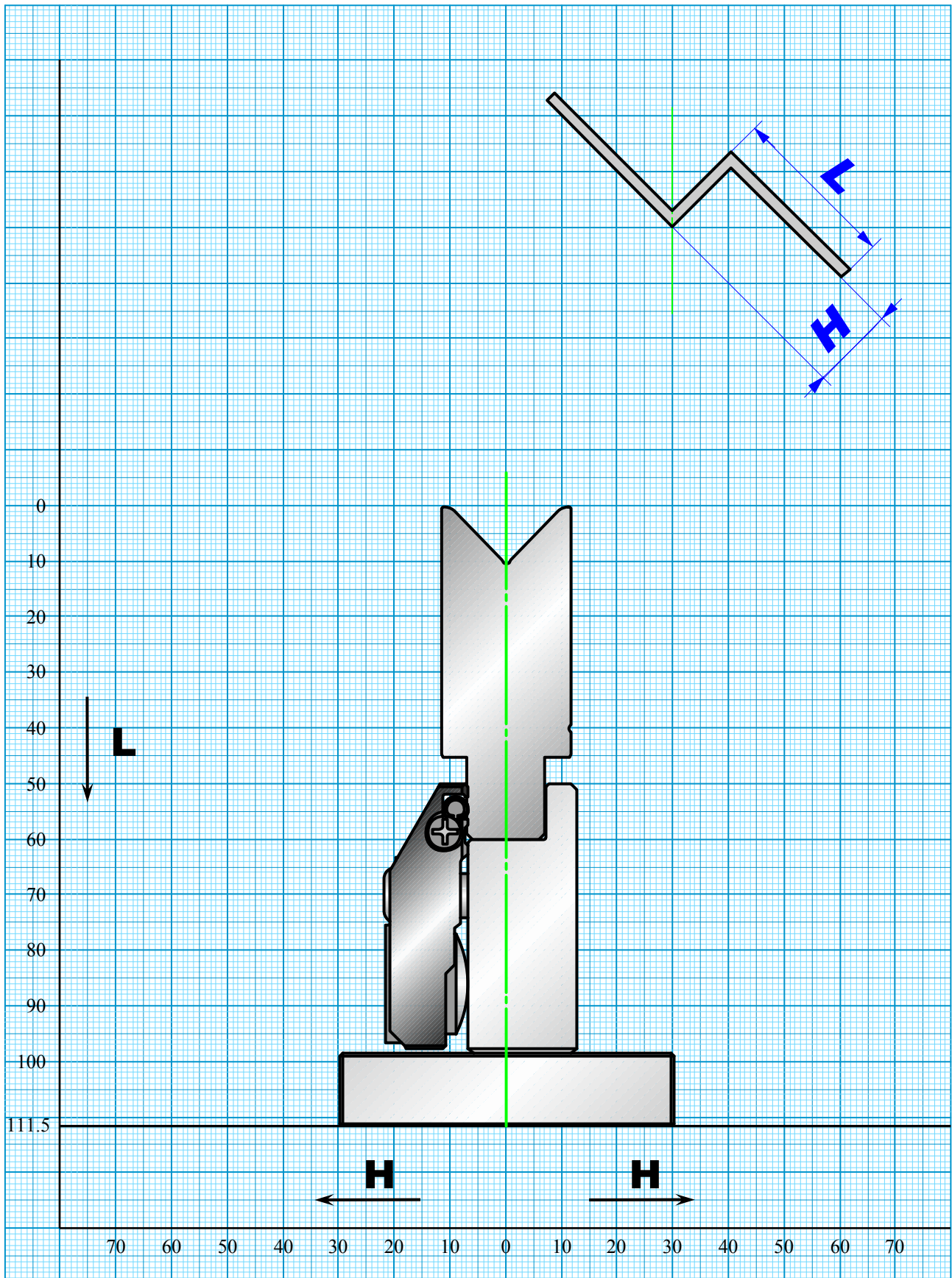



# A.F.H. T-type 1V Die V25 H=60

Allowable Tonnage 1000kN/m

88° 86°

FEAT A.F.H. Die Holder

