

# A.F.H. H=120 T-type Standard

Allowable Tonnage 800kN/m Ear: 400kN/m

GRIP:AGRIP-M

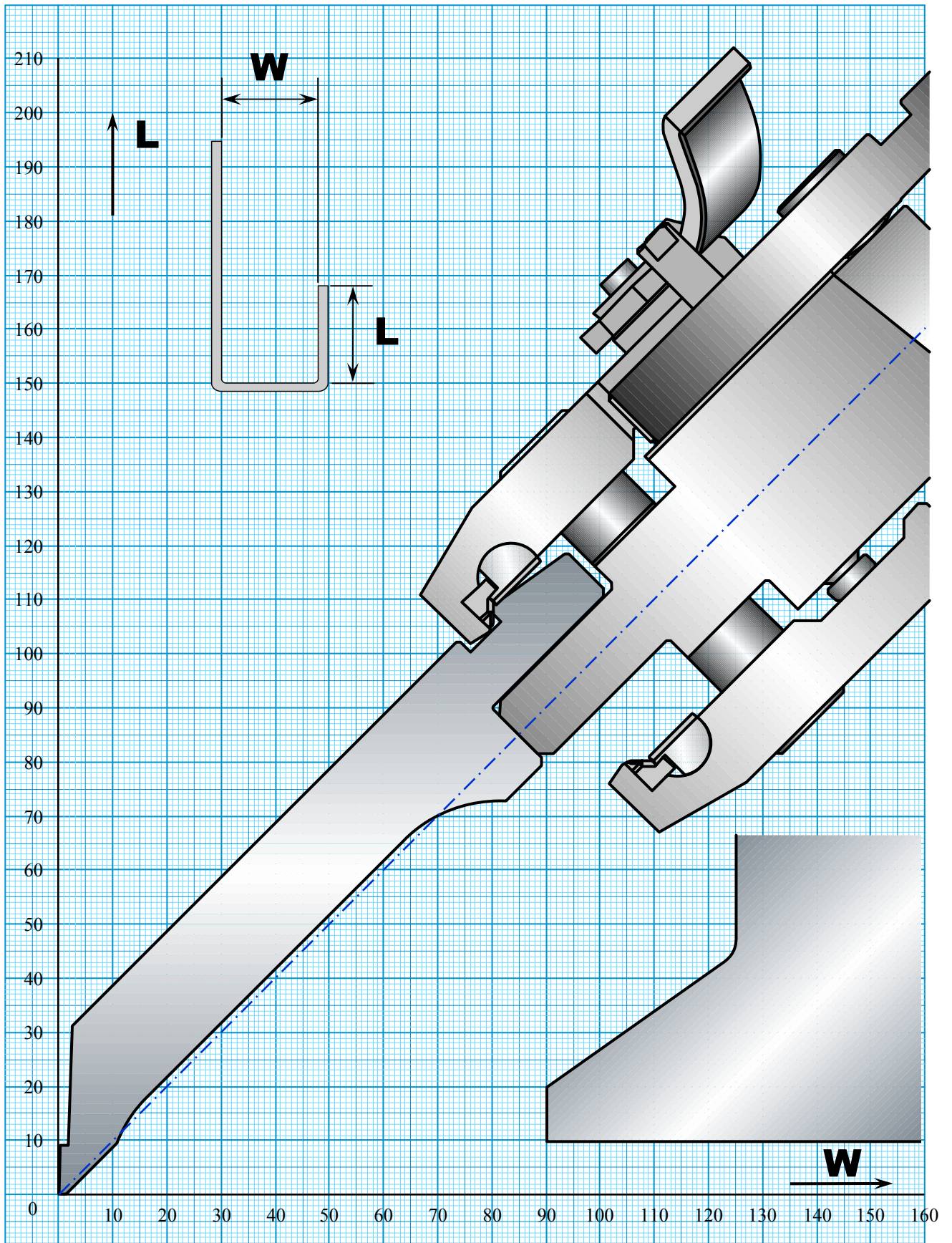

# A.F.H. H=120 T-type Sash

Allowable Tonnage 450kN/m Ear: 150kN/m

AGRIP-M

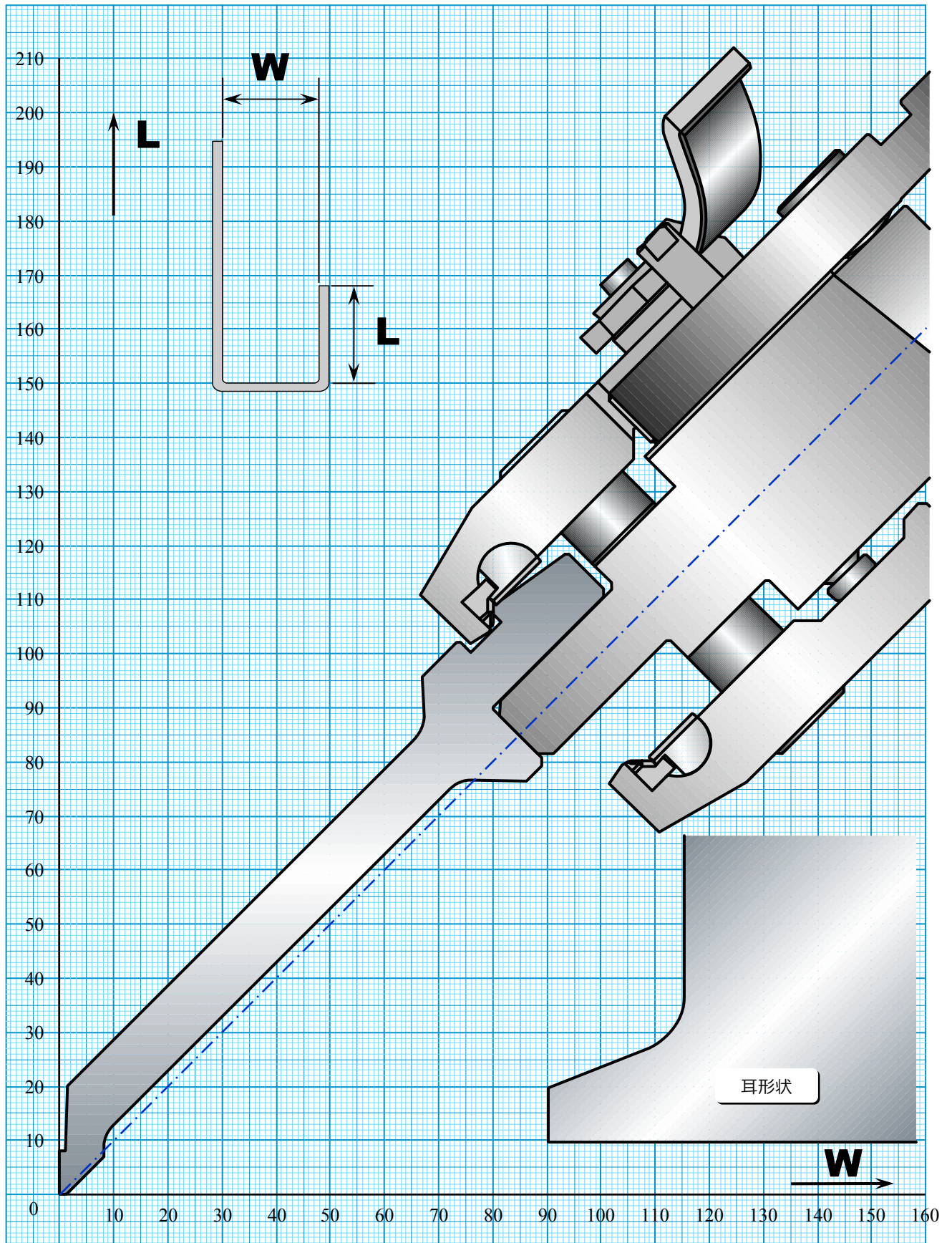

# A.F.H. H=120 T-type Straight

Allowable Tonnage 400kN/m Ear: 120kN/m

AGRIP-M

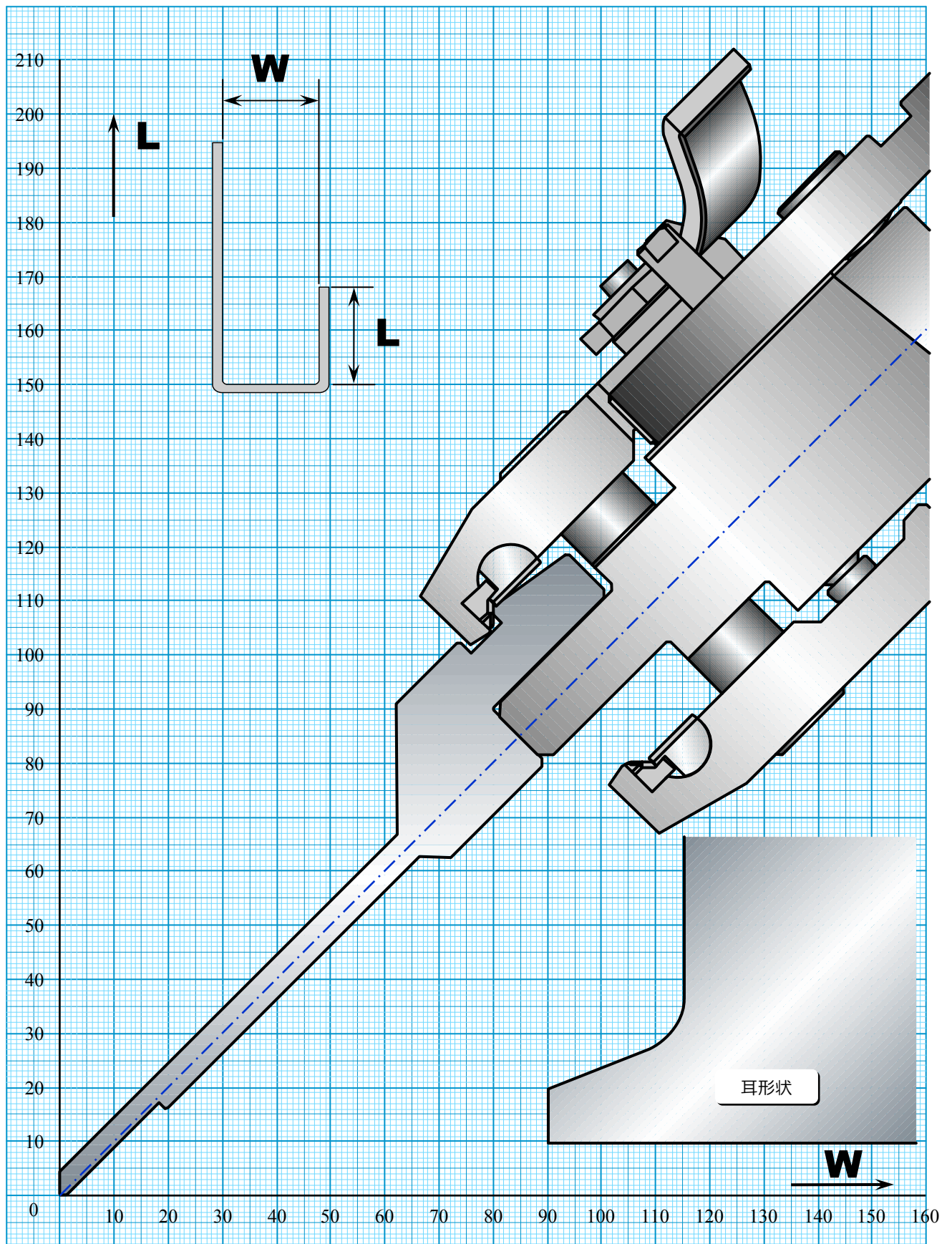

# A.F.H. H=120 T-type Gooseneck

Allowable Tonnage 500kN/m Ear: 450kN/m

AGRIP-M

