

Hydaraulic 1V Die Holder

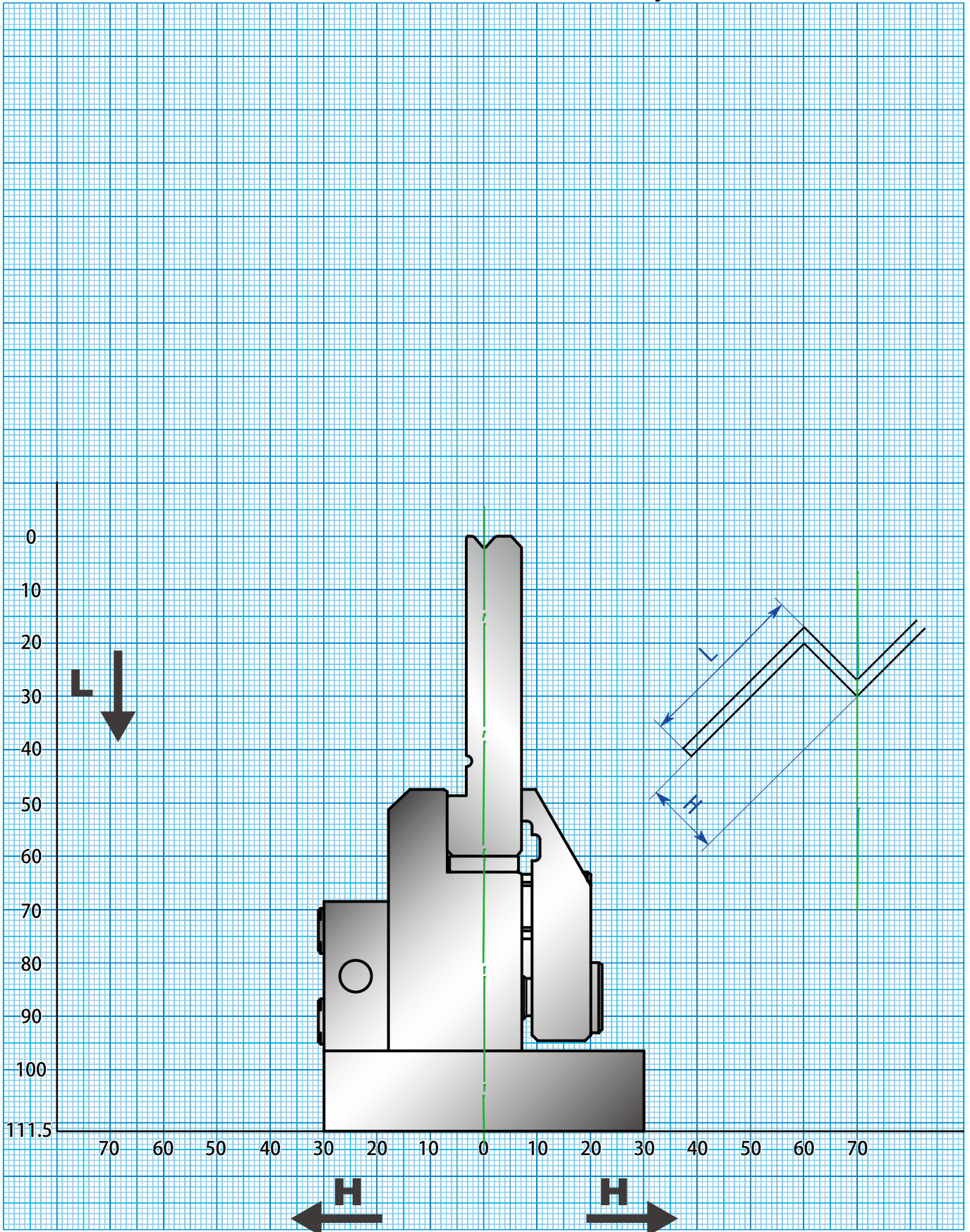

Hydaraulic 1V Die Holder

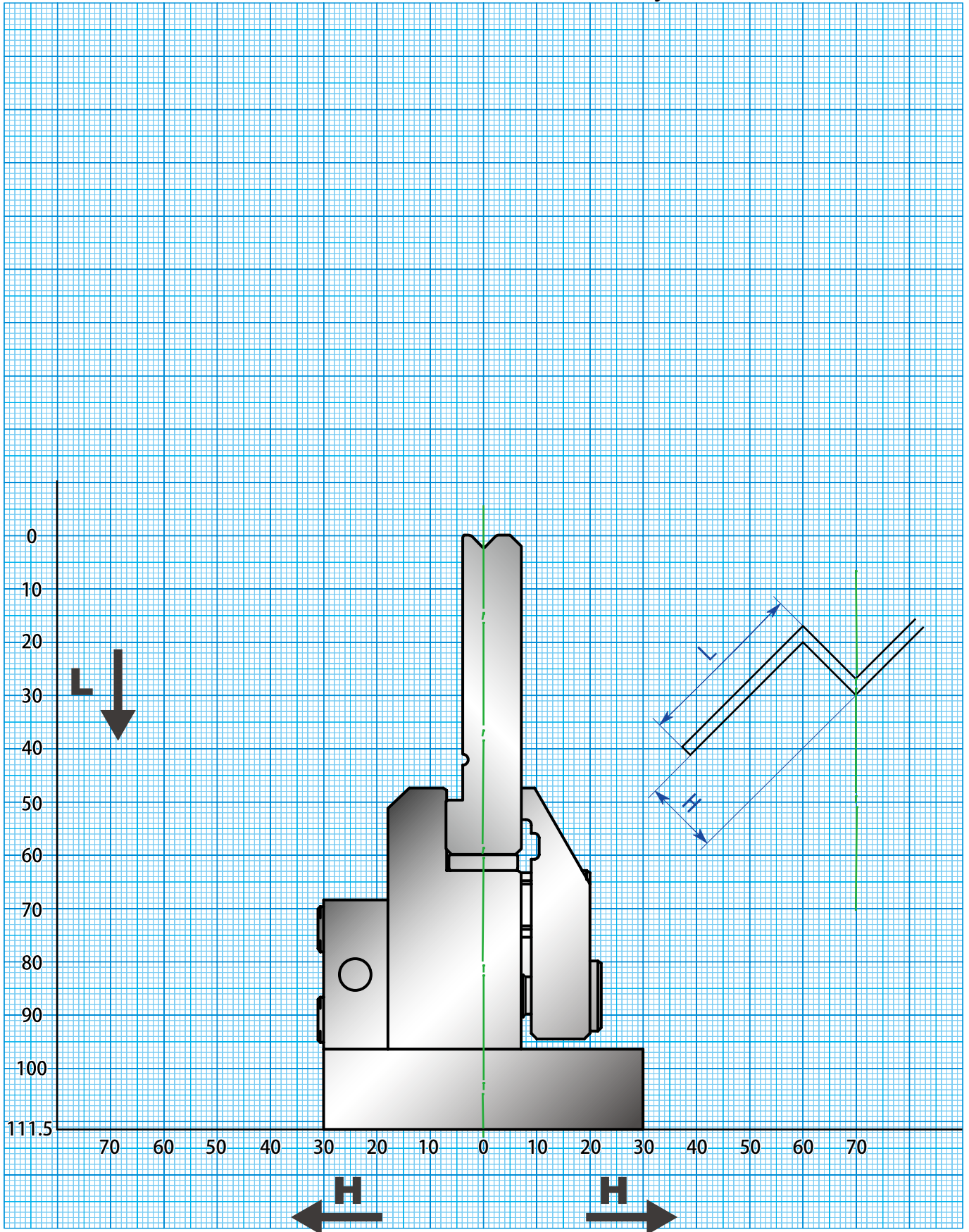

Hydaraulic 1V Die Holder

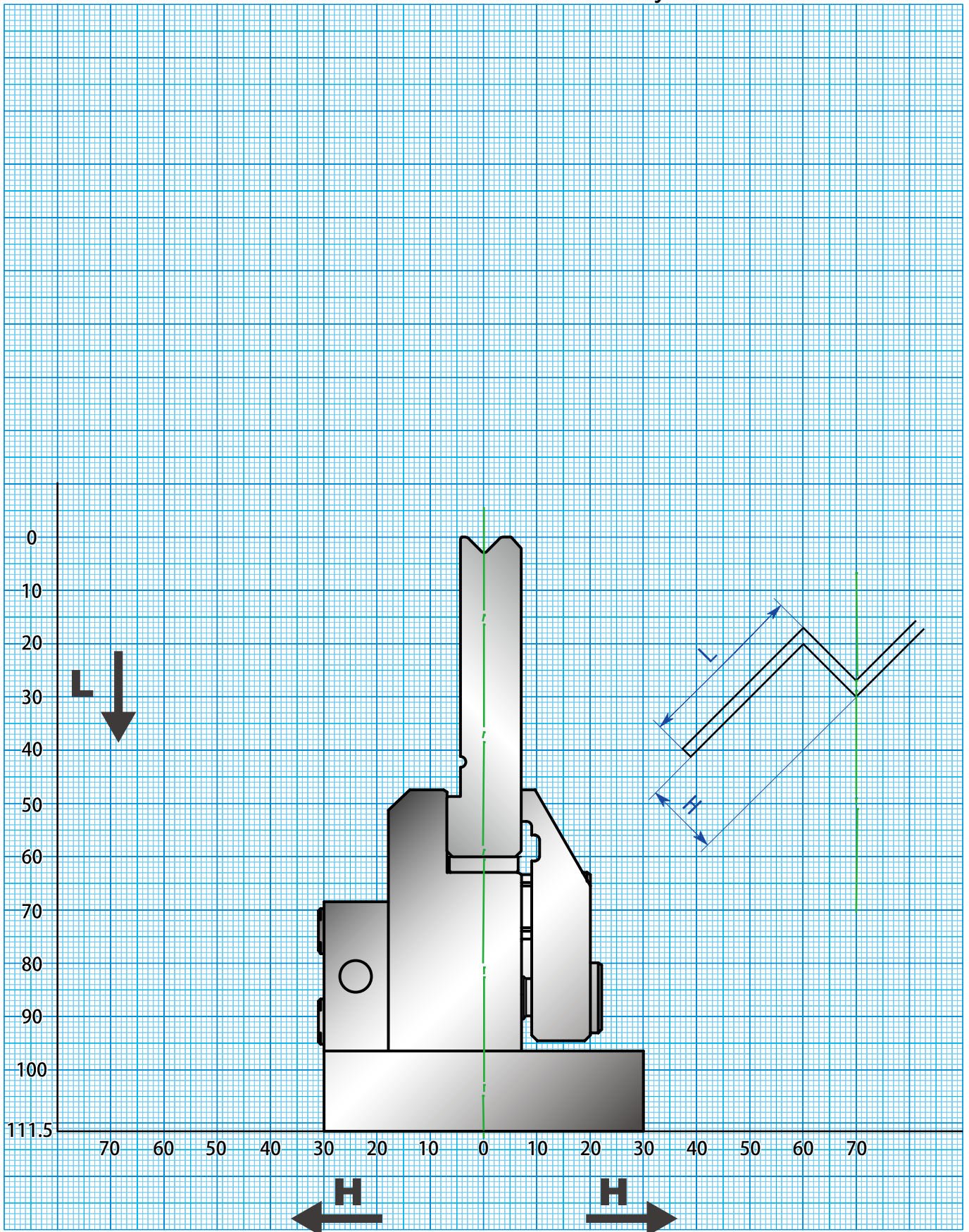

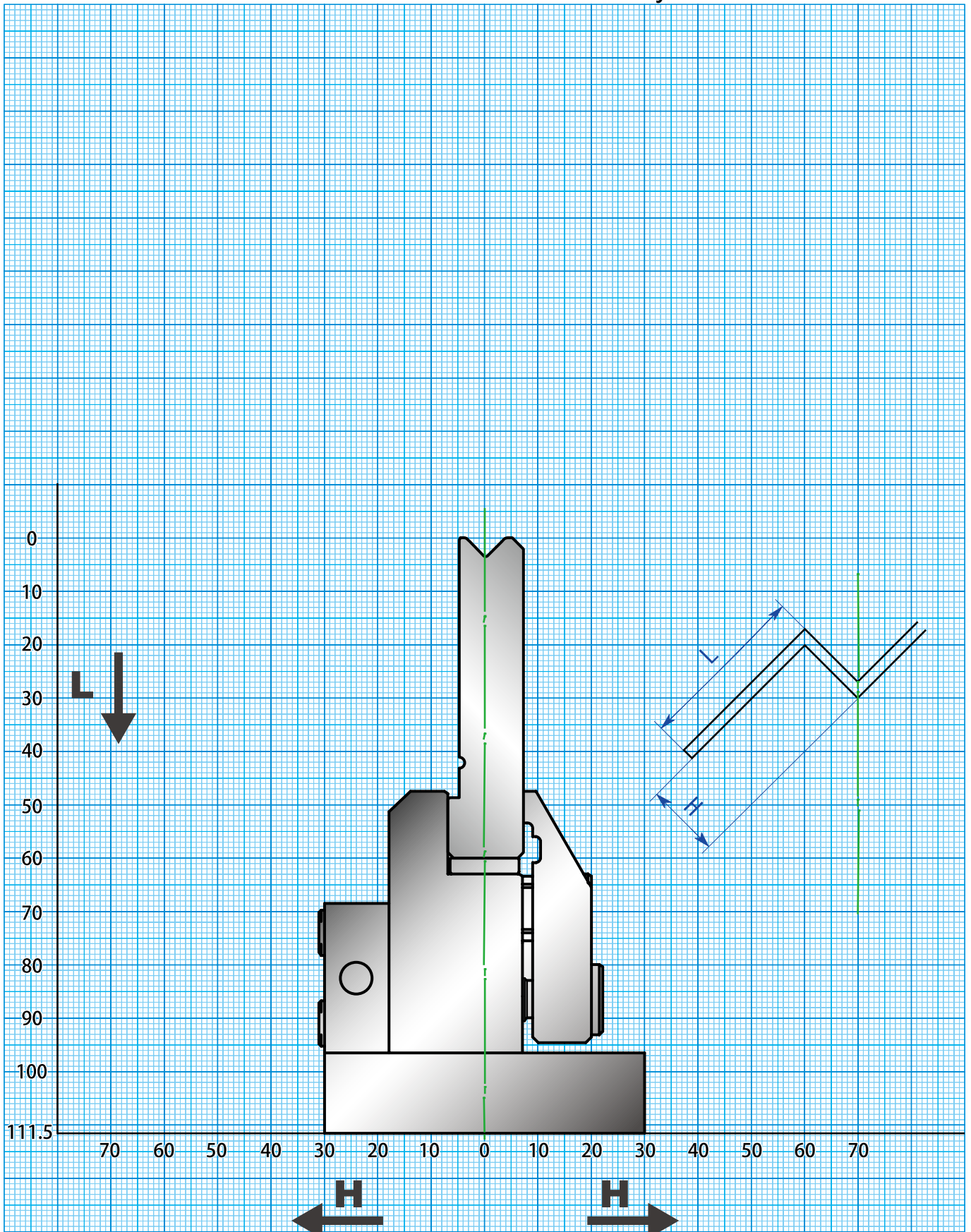



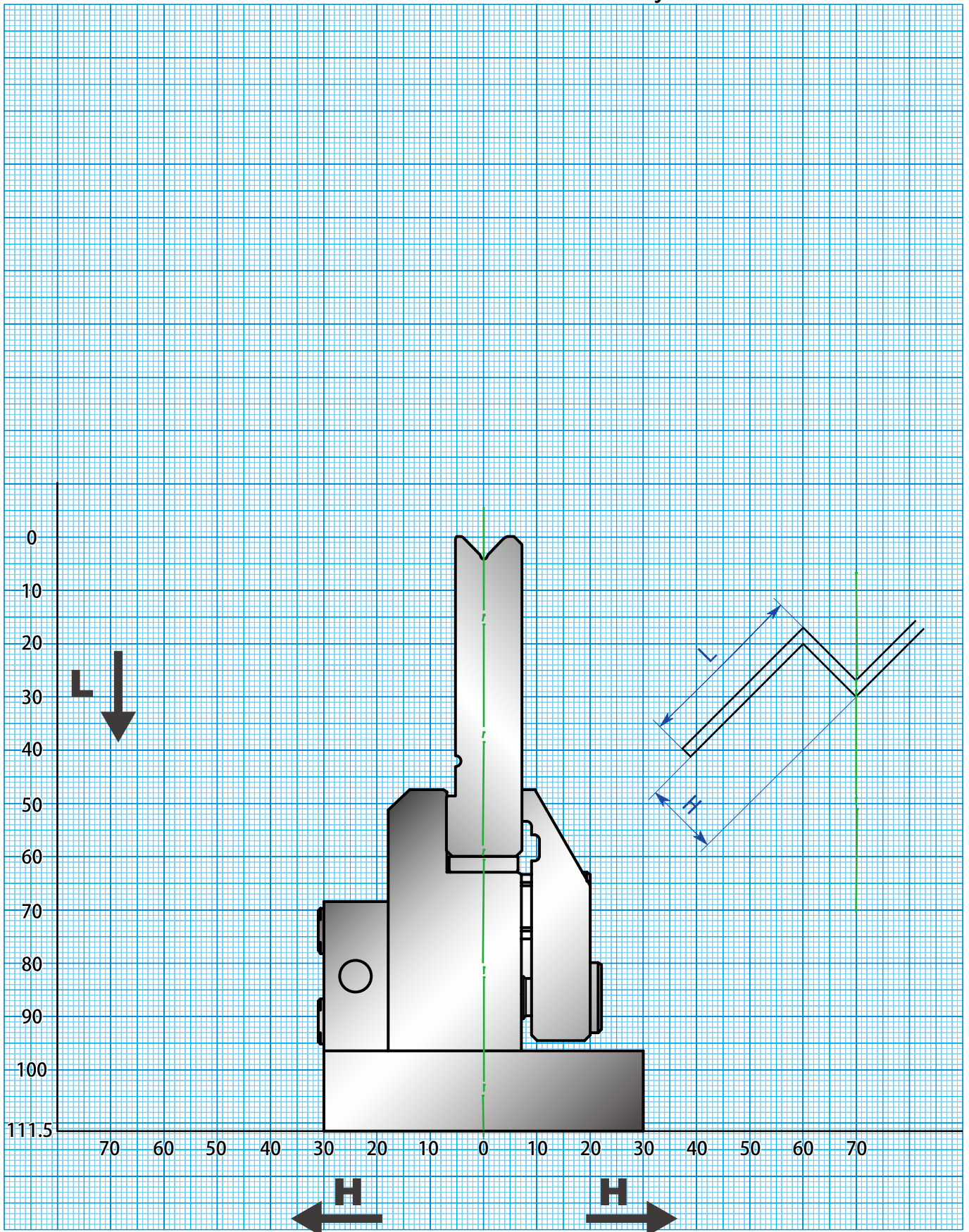

Hydaraulic 1V Die Holder

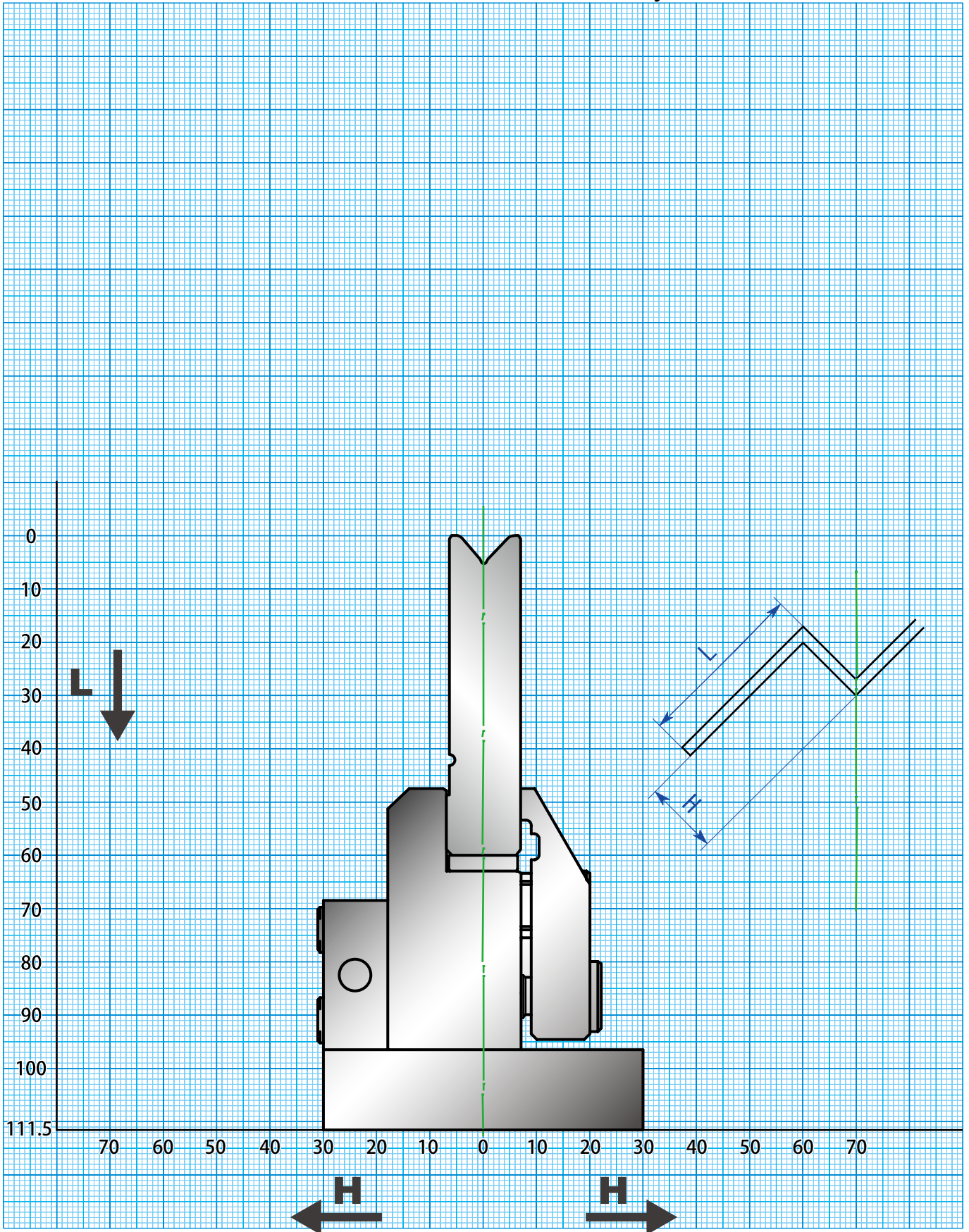

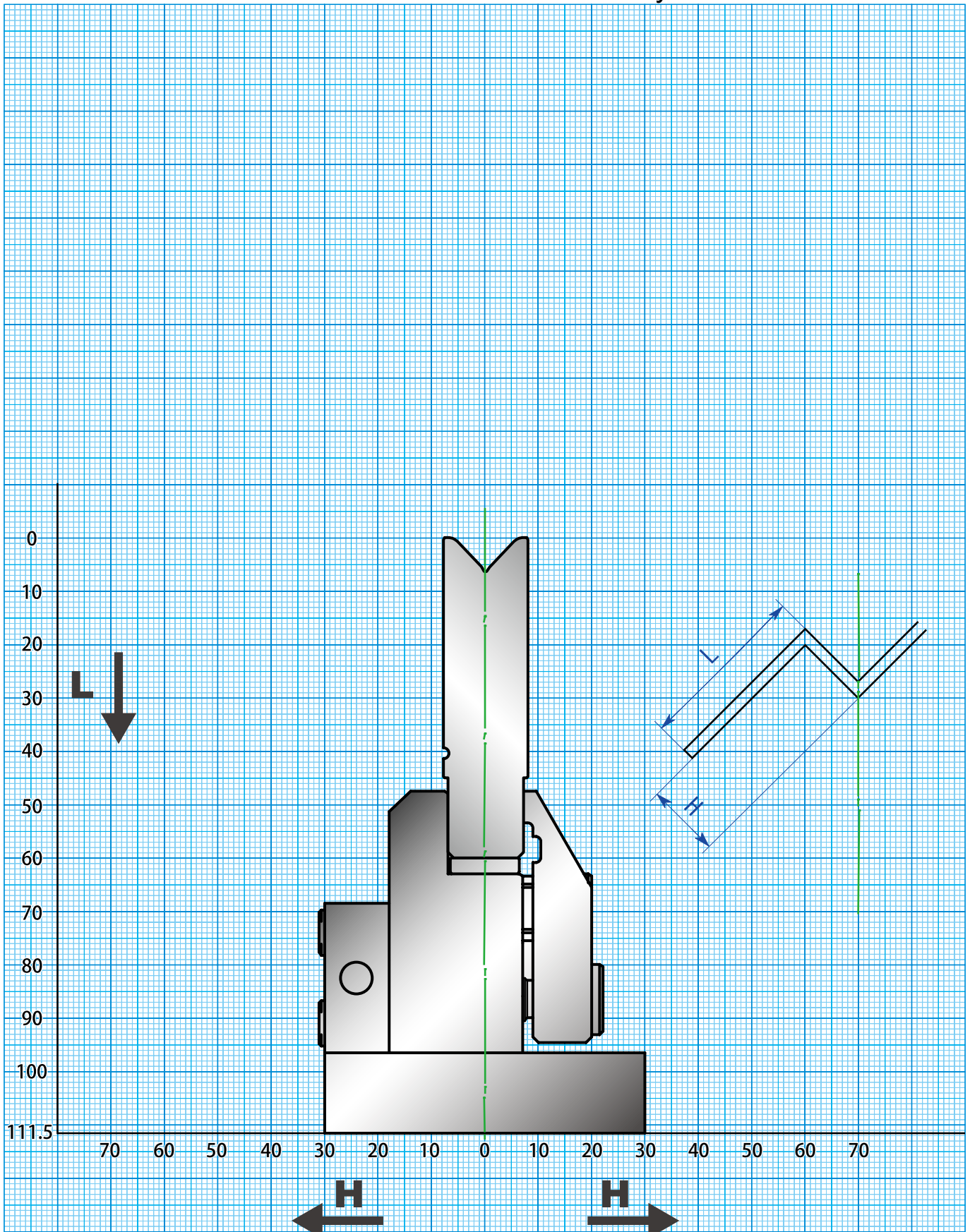

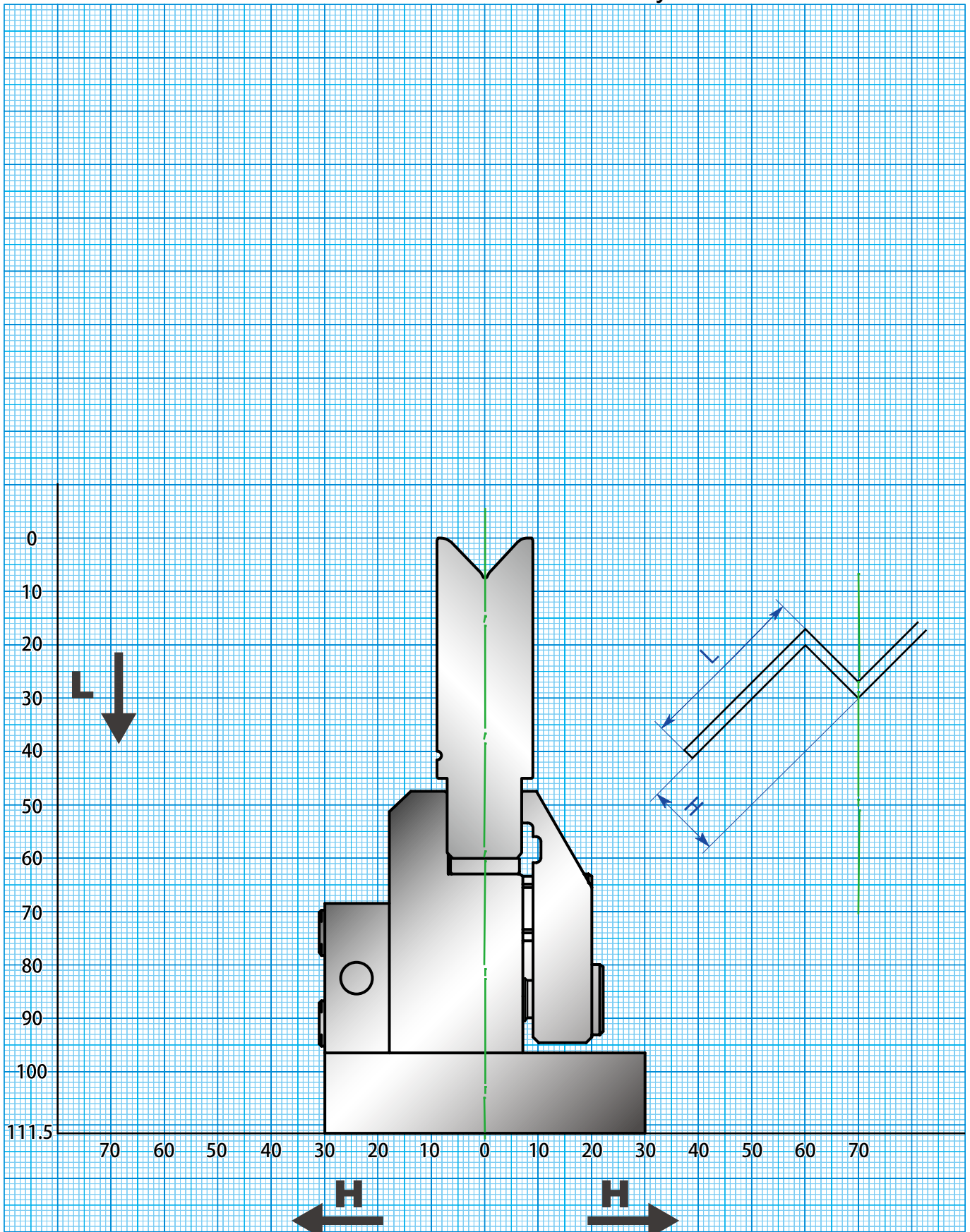

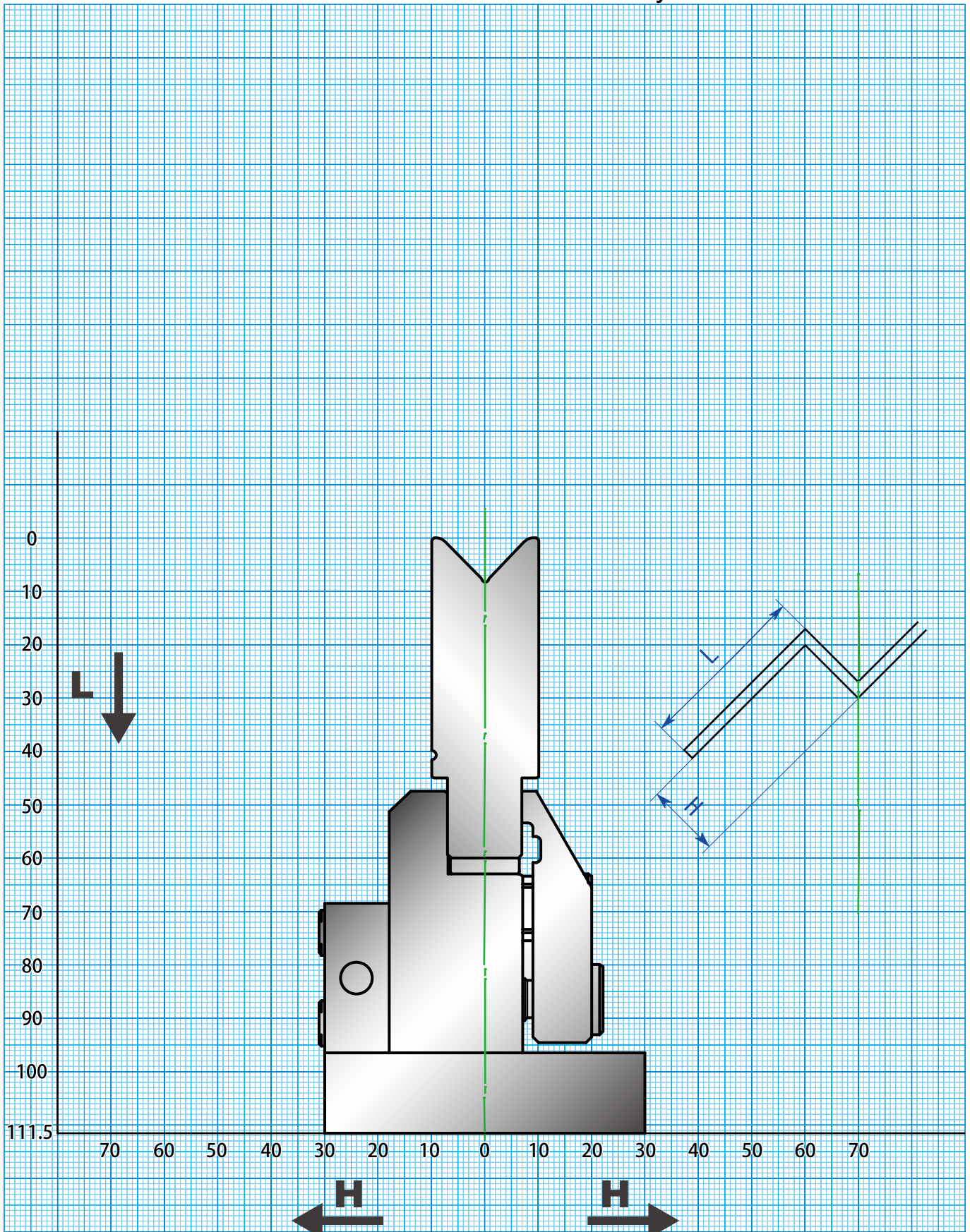

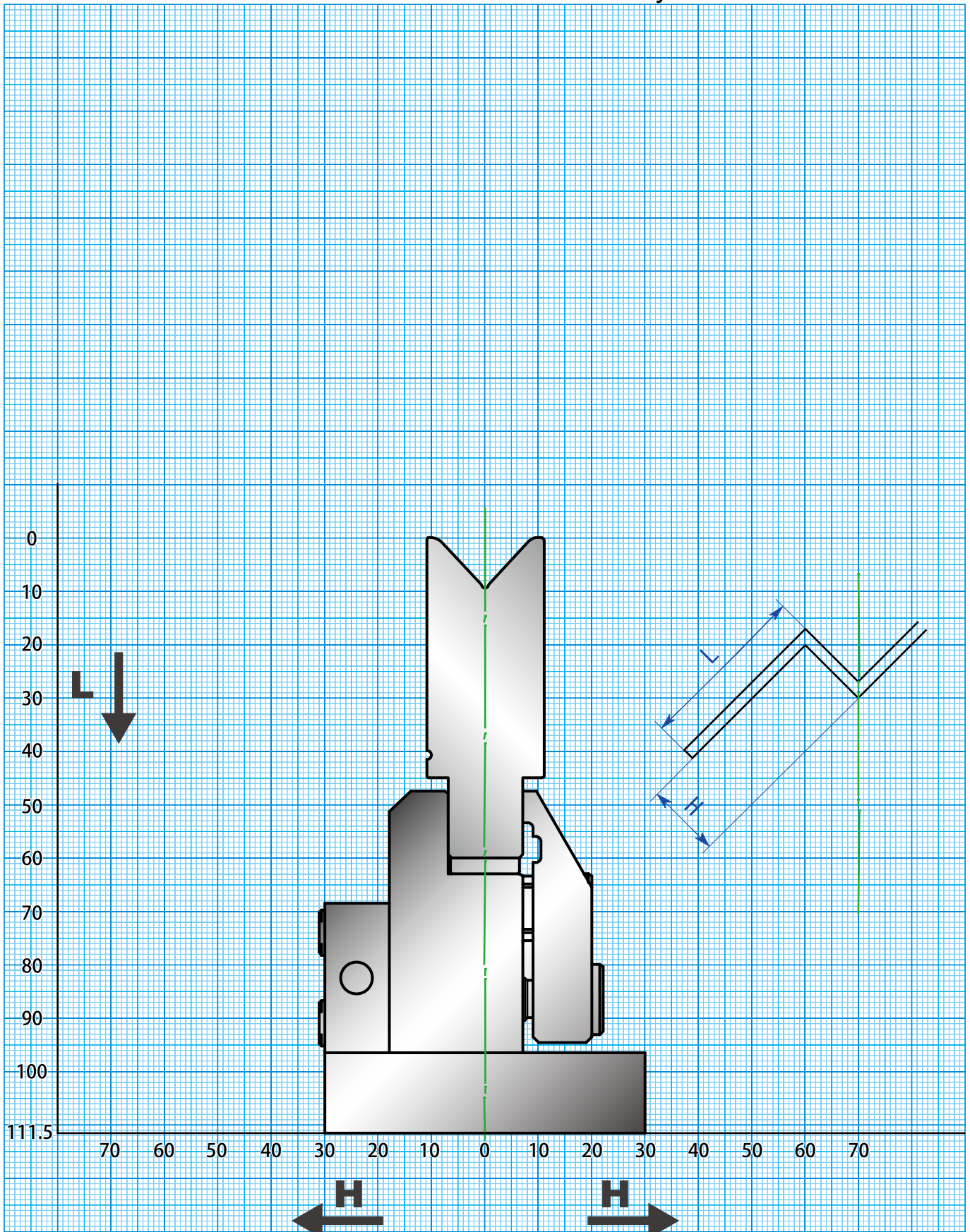

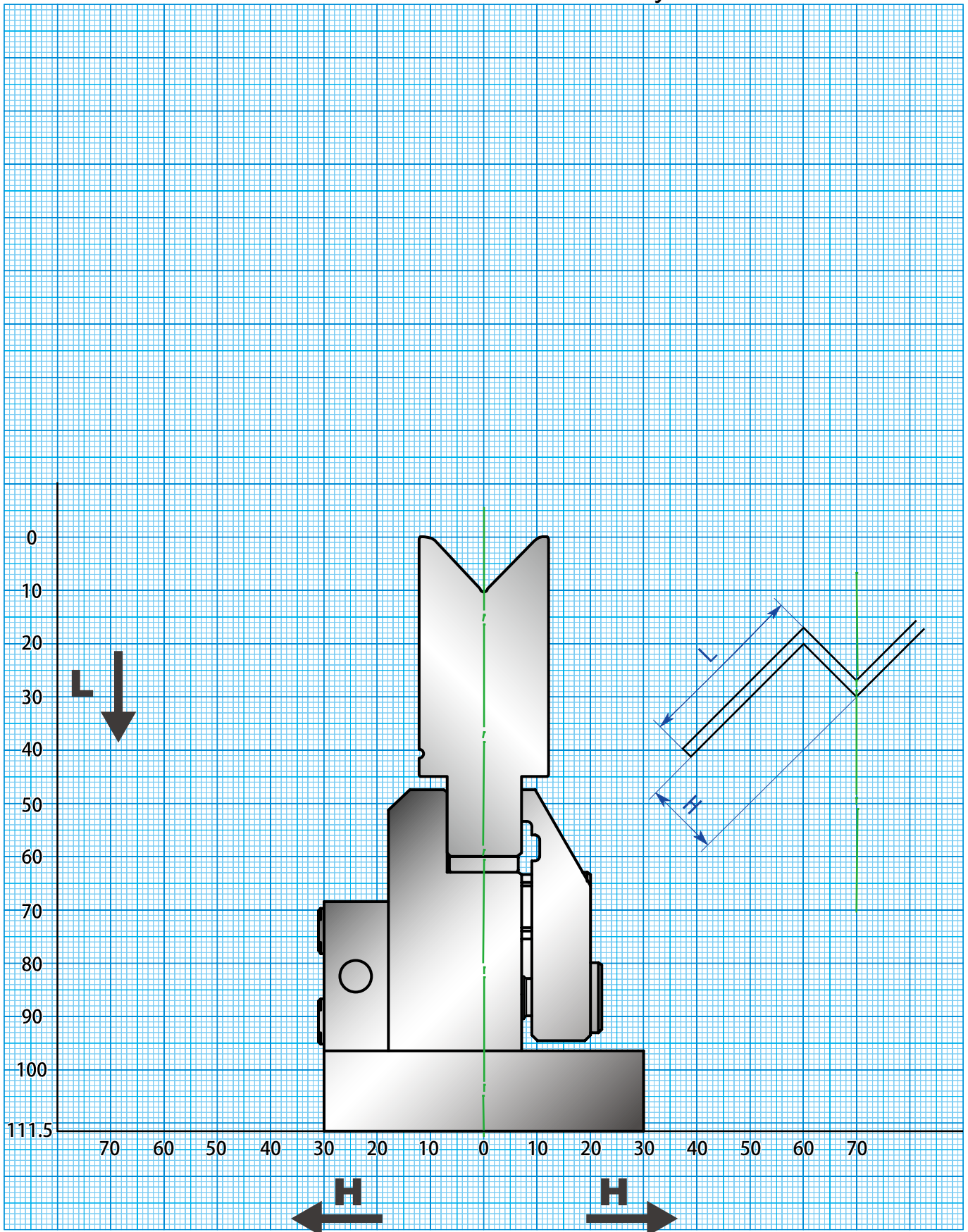

Hydaraulic 1V Die Holder

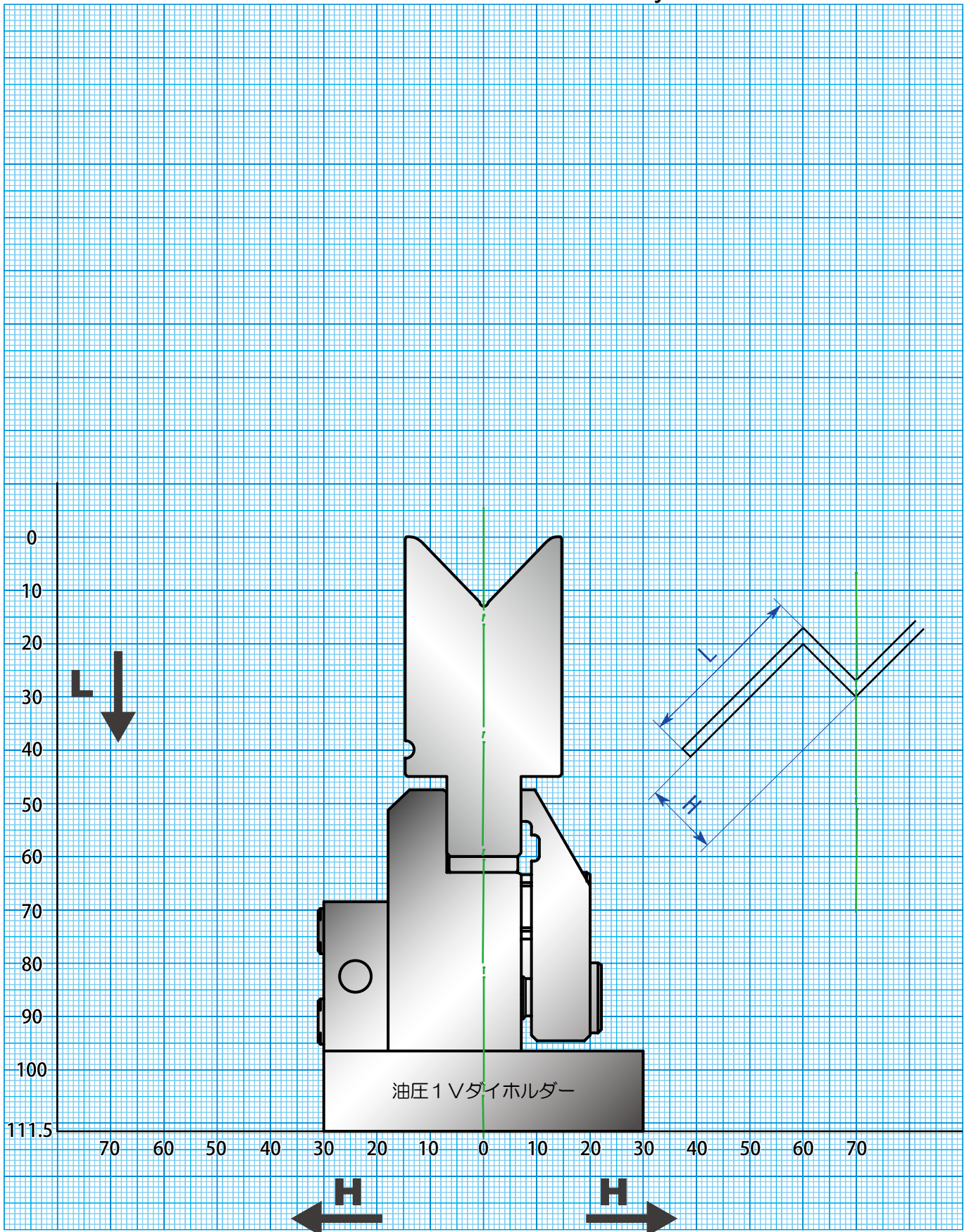



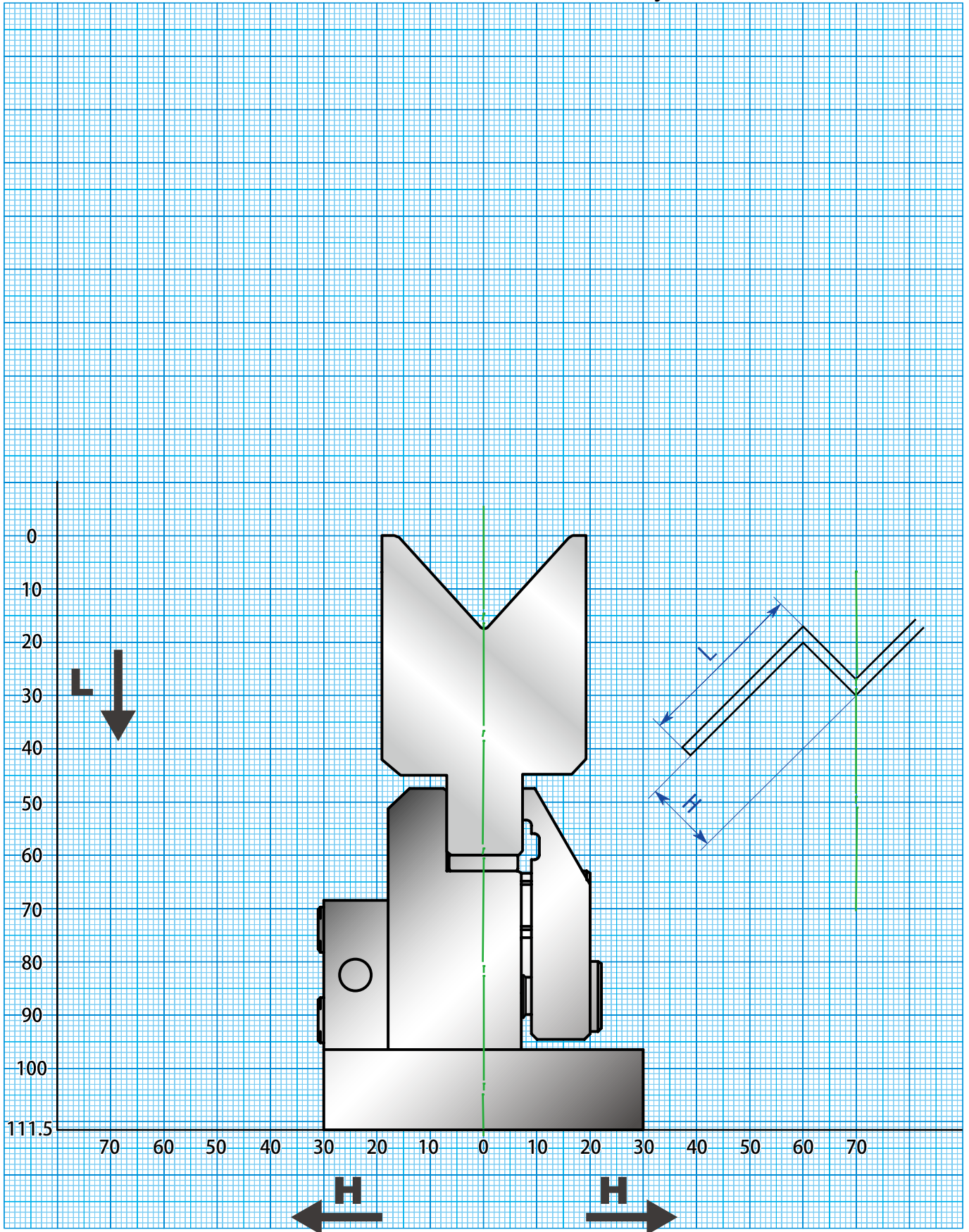

Hydaraulic 1V Die Holder

